

A GLOBAL PROVIDER OF THERMAL CUTTING TECHNOLOGY.

## THERMACUT OFFERS ELLIPTICAL-DIFFUSED INJECTION NOZZLES, UNIQUE REPLACEMENT SHIELD

Thermacut Group has created an advanced nozzle that uses an elliptical cross section to improve distribution of shield gas along the plasma arc. The ellipse allows the gas to focus the arc without the destabilizing effects caused by concentrated injection methods. The ellipse also allows the nozzle face to be smaller, bringing the cooling effect of the shield gas closer to the nozzle orifice.

### ELLIPTICAL NOZZLES AVAILABLE FOR IMMEDIATE SALE:

220439 Nozzle 260A  
220439-UR Nozzle 260A  
220542 Nozzle 260A, Bevel  
220542-UR Nozzle 260A, Bevel

Benefits of the elliptical design include increased arc stabilization and improved distribution of the shield gas resulting in **improved electrode and nozzle life** as well as **superior cut quality**.

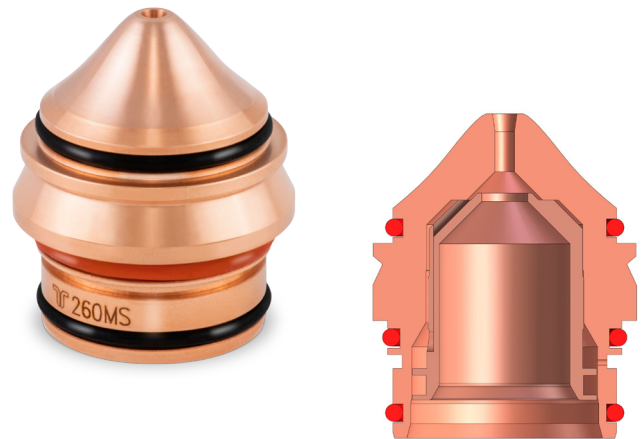

### BRIEF EXPLANATION OF THE ELLIPTICAL NOZZLE CONCEPT

The shield gas pressure and velocity increase when the size of the gas passage decreases as the gas approaches the distal end of the nozzle and shield.

The increased pressure combined with the natural friction of the gas flowing over the ellipse will keep the gas in contact with the elliptical surface. The gas will not follow any projected straight line and results in a better distribution of shield gas along the plasma arc.

This wide and laminar distribution of the shield gas greatly improves the focus of the arc while reducing turbulent flow and allows the face of the nozzle to be smaller than previously possible, thereby bringing the cooling shield gas closer to the nozzle orifice.

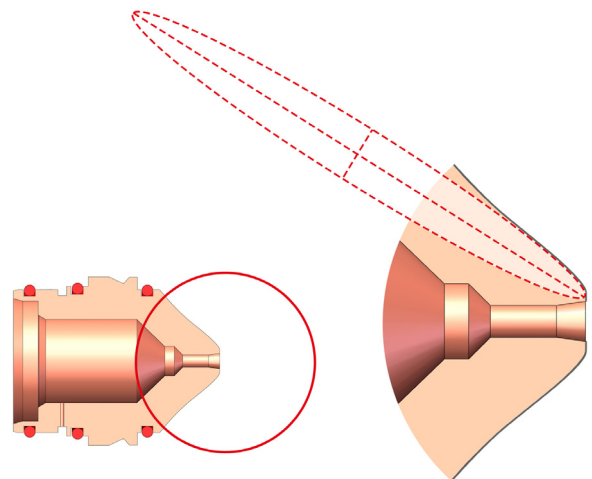

**Development:** The nozzle and shield shown here have been developed to function on a Hypertherm® HPR®260 torch and do not require any adjustment to gas pressures. The Patent Pending Elliptical Nozzle has been tested in the Thermacut Lab and resulted in increased life of the nozzle and electrode, improved arc stability and performance that was equal to or better than Hypertherm® OEM parts.

Additional prototype testing has shown that the benefits of this design work equally well when applied to Thermacut unique replacement Nozzles suitable for use with Hypertherm® POWERMAX® systems.

THERMACUT®, FHT-EX® AND EX-TRAFIRE® ARE REGISTERED TRADEMARKS OF THERMACUT, K. S. AND MAY BE REGISTERED IN CZECH REPUBLIC AND/OR OTHER COUNTRIES. ALL OTHER TRADEMARKS ARE PROPERTIES OF THEIR RESPECTIVE OWNERS. THERMACUT IS NO WAY AFFILIATED WITH HYPERTHERM®.

**THERMACUT**®  
THE CUTTING COMPANY®

SALES DEPARTMENT THERMACUT, K. S.  
DUKELSKÁ 76A, ŠENOV U NOVÉHO JIČÍNA 742 42  
TEL.: +420 556 423 440  
E-MAIL: SALES@THERMACUT.CZ  
WWW.THERMACUT.CZ

## **THE THERMACUT DIFFERENCE: THERMACUT PROVIDES YOU WITH THE CARE YOU NEED FOR YOUR COMPLEX PLASMA CUTTING SYSTEM**

**Your plasma cutting system is a complex piece of equipment. Thermacut offers not only replacement consumables, but also replacement torches and leads. We also offer you advice and training from our experienced Thermacut specialists to help you get the most out of your equipment.**

### **OUR GOAL IS TO PROVIDE A COMPLETE CARE NETWORK FOR OUR CUSTOMERS, INCLUDING:**

- Free consumable samples: put our consumables to the test on your plasma cutting system.
- **For more information please call: +420 556 423 440.**
- Supply our customers with a complete range of consumables, torches, and leads.
- Free introductory training for your plasma cutting operator.
- Providing free inspections of your torches and lead assemblies.
- Provide repairs for your damaged torches and lead assemblies.
- Training based on the most commonly-used plasma cutting systems in our lab.
- Additional products for use in the metal-cutting industry including laser and oxy-fuel.
- Control of technical conditions of cutting system.
- Measuring of conductivity of the coolant.

### **REASONS TO BUY THERMACUT PARTS:**

- Our quality is equal to OEM quality, but with a much more reasonable cost.
- Our Sales Representatives not only assist you with purchasing our products, but are also technically trained and able to provide troubleshooting help as well as advice be it over the phone or on-site.
- We are able to provide you with not just consumables, but also replacement torches and lead assemblies.
- We offer the ability to repair your worn or damaged torch and lead sets.
- We can provide technical training focused on the most commonly-used plasma cutting systems.